

ETHP-1500

UNIT SPECIFICATIONS:

POWER SUPPLY: 600 V / 3 PH / 60 HZ / 180 A
 AIR DELIVERY: 4,000 CFM
 kW: 1,500

DIMENSIONS:

LENGTH (IN): 69
 WIDTH (IN): 32
 HEIGHT (IN): 65
 WEIGHT (LBS): 967

NOTES:

- PANEL MOUNTED MAIN CIRCUIT BREAKER
- 4 CIRCUIT FIN-TUBE HEATING ELEMENTS
- SOLID STATE CONTACTORS
- ELECTRONIC TEMPERATURE CONTROL

UNIT COMPONENTS:

- (A) DISCHARGE HOOD
- (B) LIFTING EYE
- (C) CONTROL PANEL W/ SAFETY DISCONNECT
- (D) SERVICE ACCESS ELECTRICAL
- (E) INTAKE SCREEN
- (F) CAM-LOCKS®
- (G) SERVICE ACCESS COIL
- (H) SERVICE ACCESS BLOWER/BEARINGS

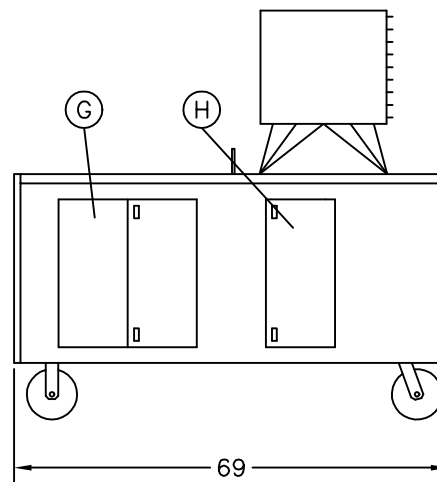
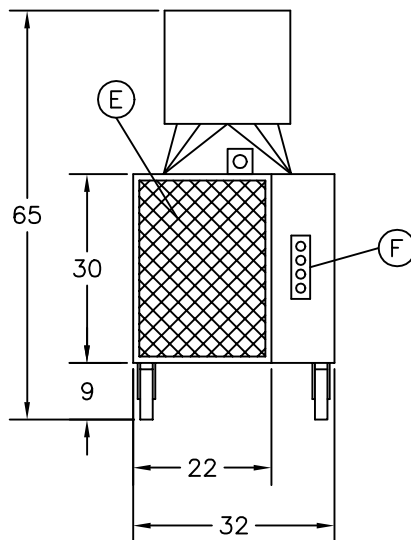
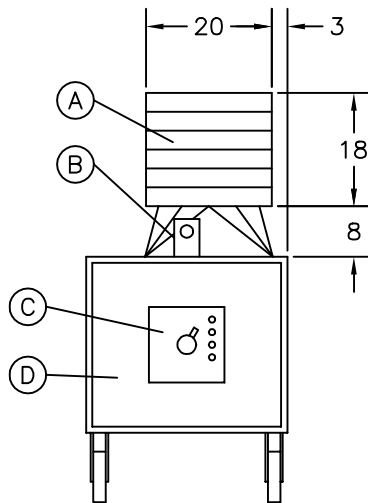

L.M. Temperature Control Inc.

DRAWN: ACJ

APPROVED: DLG

DRAWING NUMBER:

DATE: 11.15.01

DATE: 11.21.01

ETHP1500